

# HAMPTON THUMB LATCH (Item # 4300-WSP)

## INSTALLATION INSTRUCTIONS

### FOR WOODEN GATES

#### Specifications:

Flush mount (latch bar side of gate must be flush with posts). This latch can be mounted either on the right or left side of the gate.

Space between gate and post:	0.75" is ideal but it can be between 0.5" and 1.0" (if less than 0.5" required then latch plate and post latch may be mortised to flush)
Mounting Rail Width:	3" minimum (less if installed at level of a flush horizontal cross member)
Mounting Rail Thickness:	Use the Short thumb bar for gate thicknesses 1.5" to 3.0" Use the Long thumb bar for gate thicknesses 3.0" to 5.0"
Tools Required:	Philips screwdriver 3/4" drill bit and drill (forstner bit recommended to minimize tear out)

#### Installation Instructions:

- At the desired height, use the latch plate as a template. Place it on the side of the gate that will be flush with the posts.
- Use a pencil to trace around the inside of the vertical slot in the latch plate on the gate.
- Mark a drilling center that is 3/8" above the bottom of the slot marked on the gate and centered between the two sides of the slot. (Center of hole should be 2 1/16" from the edge of the gate) **Always drill from the latch plate side of the gate.**
- Drill a single 3/4" hole through the gate avoiding excessive break out on the other side. (The entire slot does not have to be drilled out)
- Install the latch plate on the gate ensuring the bottom of the slot is level with the bottom of the drilled hole.
- Install 2 (1.0" x #8) screws in the end of the latch plate into the edge of the gate. Then install 1 (1.0" x #8) into the countersunk hole on the face of the latch plate (Please note: We also recommend that all screws holes are pre-drilled to accept the appropriate size screw).
- Install latch bar so that the thin end is tucked under the loop in the latch plate. (Start with the bar perpendicular to the plate, tuck the first tooth behind the loop, and drop the latch bar toward the latch plate until it is resting on it and between the two round protrusions on the latch plate)
- Place the locking bar on the top round protrusion as per the diagram.
- Place the retainer so that the small rectangular protrusion on the back is facing down and is installed below the latch bar. Fasten the retainer to the gate using the 2 (2.0" x # 12) screws provided.
- Install the thumb bar into the back of the handle by pushing the thumb knob through the handle and rotating it 90 degrees. The two pins on the thumb bar will then sit in the recesses on the back of the handle.
- Push the curved end of the thumb bar through the hole in the gate so that it extends through the slot in the latch plate underneath the latch bar. Fasten the handle so that the bar is in center of the hole (use 3 (1.25" x #10) screws)
- Push the gate to the closed position and mark the gate post at the point where the bottom of the latch bar touches the post.
- Install the catch plate on the inside face of the gate post using 2 (1.5" x #8) screws, so that the bottom of the slot is 1/4" below the mark made on the latch post in #12 above.

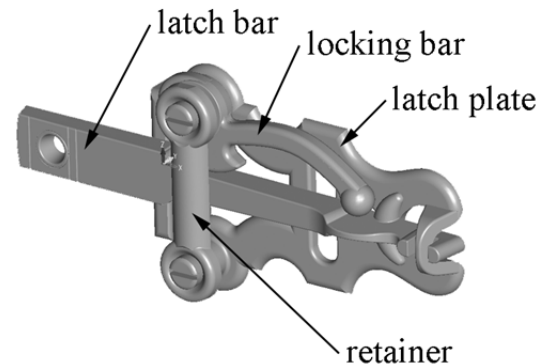
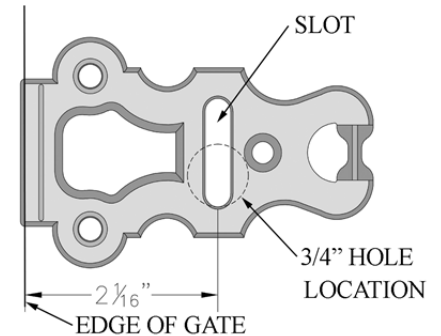

We strongly recommend the use of our gate stop (item#1400-BSS) or a wooden stop block on the latch post to absorb the force of the gate closing and avoid putting undo stress on the latch components.

**Failure to install a stop block or gate stop voids any warranty this product may carry.**



Printed in the USA